

JBC

www.jbctools.com

INSTRUCTION MANUAL



NHS

Stand for NH High Precision
Heater Hose Set

This manual corresponds to the following references:

NA-SA

Packing List

The following items are included:



Stand 1 unit



Stand Cable 1 unit
Ref. 0023953

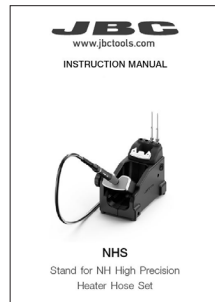

Manual 1 unit
Ref. 0024827

Features and Connections

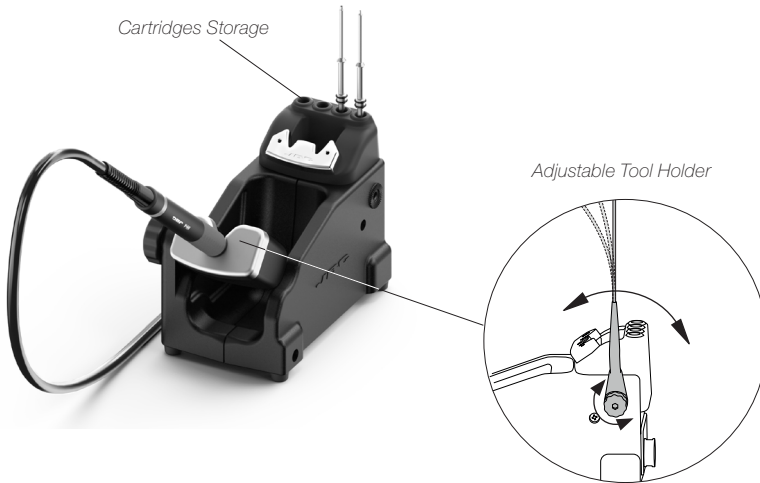
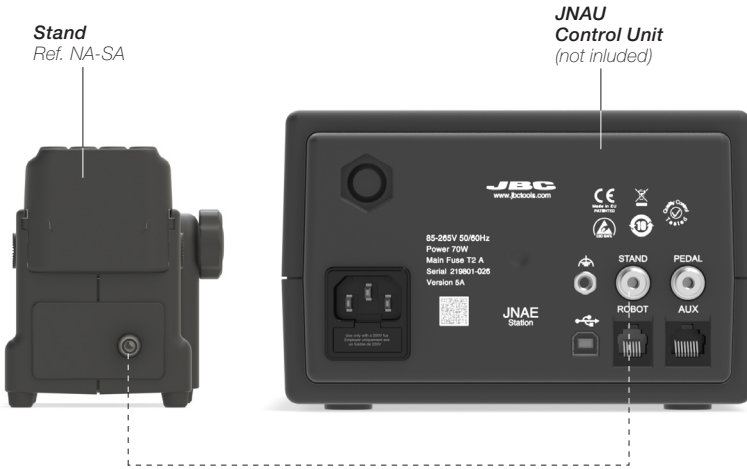

Adjust the tool holder angle to suit your work position.

Quick Tip Changer

Save time and change cartridges safely without switching the station off.

1. Removing

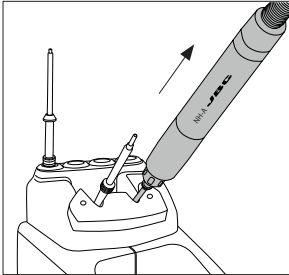

Place the cartridge in the extractor and pull the handle to remove the cartridge.

2. Inserting

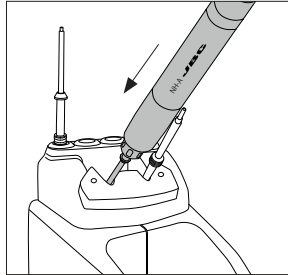

Place the handpiece on top of the new Cartridge and press down slightly.

3. Fixing

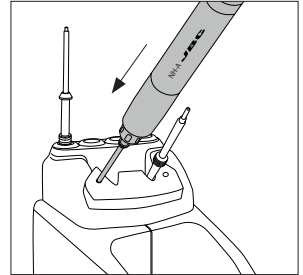

Use the holes to push and fix the cartridge in its final position.

*Important

It is essential to insert the cartridges as far as the mark for a proper connection.



Compatible Cartridges *(Not included)*

The JNA High Precision Hot Air Station works with J125 Cartridges and NH High Precision Heater Hose Set.

Find the model that best suits your soldering needs in www.jbctools.com

J125010

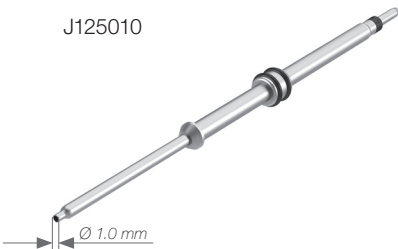

J125015

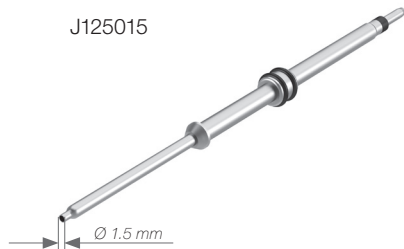

Maintenance

Before carrying out maintenance or storage, always unplug the stand from the station and the tool.

- Use a damp cloth to clean the stand. Alcohol can be used only when cleaning the metal parts.
- Check periodically that the metal parts of the tool/stand are clean so that the station can check the tool's status.
- Periodically check all cables and tube connections.
- Replace any defective or damaged parts. Use original JBC spare parts only.
- Repairs should only be performed by a JBC authorized technical service.

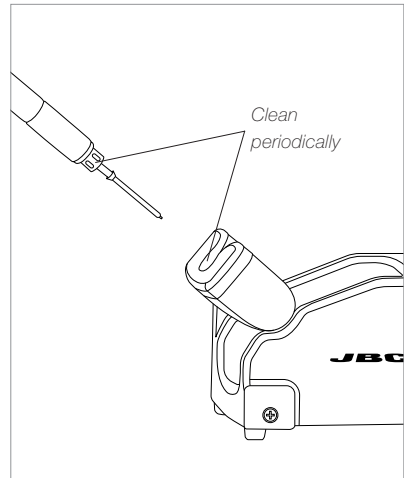

Safety



It is imperative to follow safety guidelines to prevent electric shock, injury, fire or explosion.

- Do not use the stands for any purpose other than soldering or rework.
- The power cord must be plugged into approved bases. Be sure that it is properly grounded before use. When unplugging it, hold the plug, not the wire.
- The tool should be placed in the stand when is not in use in order to activate the sleep mode. The soldering tip, the metal part of the tool and the stand may still be hot even when the station is turned off. Handle with care, including when adjusting the stand position.
- Avoid the contact of flux with skin or eyes to prevent irritation.
- Be careful with the fumes produced when soldering.
- Keep your workplace clean and tidy. Wear appropriate protection glasses and gloves when working to avoid personal harm.
- Utmost care must be taken with liquid tin waste which can cause burns.
- This appliance can be used by children over the age of eight and also persons with reduced physical, sensory or mental capabilities or lack of experience provided that they have been given adequate supervision or instruction concerning use of the appliance and understand the hazards involved. Children must not play with the appliance.
- Maintenance must not be carried out by children unless supervised.

Specifications

NA-SA

- Includes Automatic "Tool-In-Stand-Detection"
- Net Weight 1.18 kg (2.61 lb)
- Total Package Dimensions/Weight: 342 x 155 x 120 mm / 1.57 kg
(L x W x H) 13.46 x 6.10 x 4.72 in / 3.47 lb

Complies with CE standards
ESD protected

JBC

Warranty

JBC's 2 year warranty covers this equipment against all manufacturing defects, including the replacement of defective parts and labour.

Warranty does not cover product wear or misuse.

In order for the warranty to be valid, equipment must be returned, postage paid, to the dealer where it was purchased.

Get 1 extra year JBC warranty by registering here:
<https://www.jbctools.com/productregistration/>
within 30 days of purchase.



This product should not be thrown in the garbage.

In accordance with the European directive 2012/19/EU, electronic equipment at the end of its life must be collected and returned to an authorized recycling facility.



www.jbctools.com