



A Donaldson Company

A WORLD LEADER IN FUME EXTRACTION TECHNOLOGY



FumeCAB 1000 iQ

ELECTRONICS, PHARMACEUTICAL & MEDICAL

Last Updated on 14.09.2018



The complete cabinet fume extraction solution for a broad range of applications.

Partial enclosures are becoming the recommended extraction option for a variety of applications. Government bodies, including the HSE are now making direct reference through guidance documentation such as the HSG258 to their use.

The FumeCAB 1000 iQ integrated filtration system has been designed to ensure compliance with the latest regulations. It provides users with an extra depth of working space for taller applications.

BOFA's iQ Operating System and ultrabright slimline energy saving LED lights come as standard making this system an ideal choice of fume extraction for a wide variety of applications.

More information about the [Intelligent \(iQ\) Operating System](#).

Technology



Intelligent (iQ) Operating System



HEPA filter



Automatic flow control (AFC) technology



Reverse flow air (RFA) technology



Advanced carbon filter (ACF) technology



Patented technology



ProTECT service plan



SureCHECK quality standard

Key features of the FumeCAB 1000 iQ

Certified to BS 7989:2001 Recirculatory filtration fume cabinet specification Standard

Reverse flow filter technology Standard

Ensures operational compliance with HSG258 guidelines Standard

Automatic flow control system Standard



Energy saving ultra-bright slim line LED lighting
Standard

Combined HEPA / Gas filter incorporating ACF technology
Standard

Real time airflow reading
Standard

High contrast display
Standard

Remote diagnostics via USB
Standard

Side entry blind grommets for equipment access
Standard

Interfacing
Optional

Stand
Optional

Twin coated anti UV / anti splash protective Polycarbonate visor
Standard

Filters with long life and low replacement cost
Standard

Independent filter condition monitoring, display and warnings
Standard

'Run safe' operation
Standard

Large working area
Standard

VOC gas sensor (Volatile Organic Compound)
Optional

UV lighting
Optional

Optional filter medias
Optional

Technical specification

1. iQ display

2. On / Off switch

3. Filter compartment hinges

4. Cable entry grommet

5. Transparent visor

6. Hinges

7. Mains inlet

8. LED lighting

9. Exhaust

10. Cooling air inlet

11. Standby button

12. UV lighting (optional)



Left Side / Internal work area

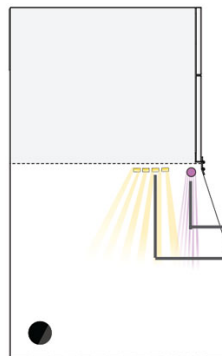

Back

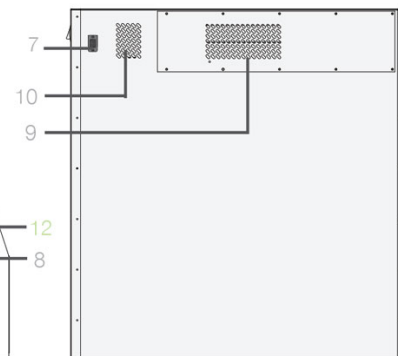

Internal work area and optional stand

13. Stand (optional)

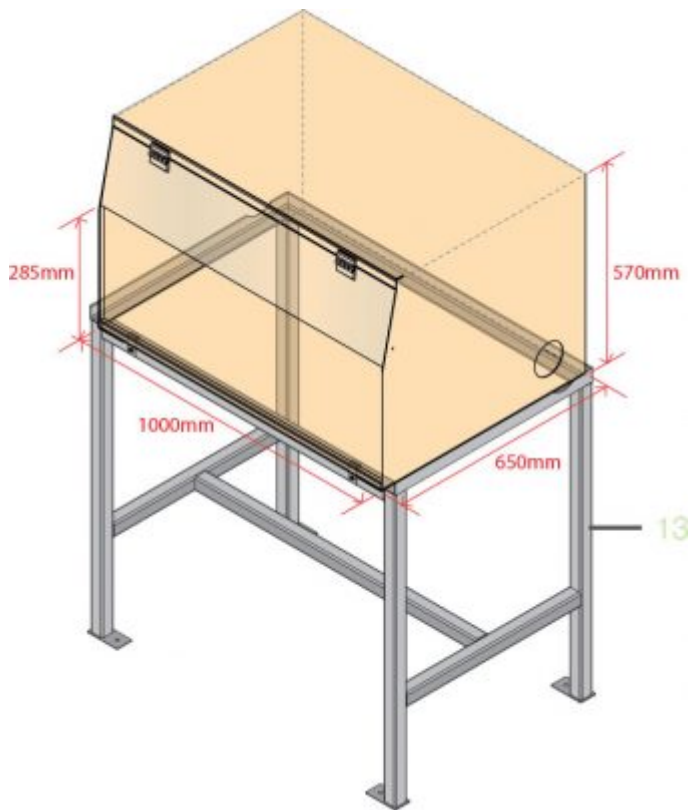

Airflow through filters

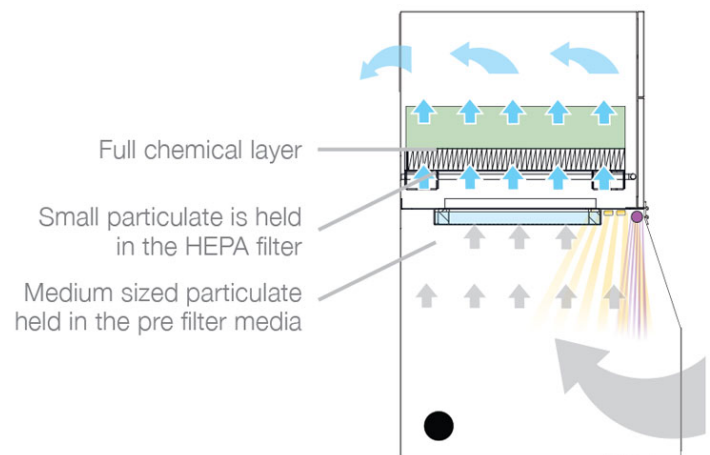
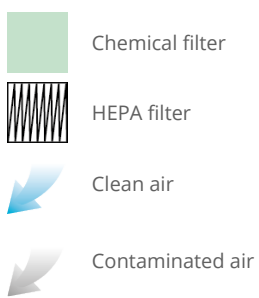

Technical data

	EU	US
Dimensions (HxWxD)	1003 x 1000 x 655mm	39.49 x 39.37 x 25.79"
Opening dimensions (HxWxD)	285 x 1000 x 650mm	11.2 x 39.4 x 25.6"
Cabinet construction	Powder coated mild steel	Powder coated mild steel
Face velocity	0.4m/s	78.7ft/min

Technical data

Max face velocity	0.6m/s	118ft/min
Electrical data	230v 50/60Hz Full load current: 6 amps	115v 50/60Hz Full load current: 10 amps
Noise level	< 60dBA (At typical operating speed)	< 60dBA (At typical operating speed)
Weight	120kg	264lbs
Exhaust outlet (Optional)	125mm	125mm
Approvals	CE	CE

Pre filter specifications

Filter media construction	Filter pad
Filter housing	Cardboard
Filter efficiency	99% @ 0.3 microns

Combined HEPA/Gas filter specifications

HEPA filter media	Borosilicate
HEPA media construction	Pleated with glue bead spacers
Filter housing	Zintec mild steel
Treated activated carbon	17kgs (37.4 lbs)
Filter efficiency	99.997% @ 0.3 microns

Optional stand specifications

Dimensions (HxWxD)	943 x 1029 x 669mm / 37.1 x 40.5 x 26.3"
Stand Construction	Powder coated mild steel

Unit part numbers

Model	Voltage	Part No.
FumeCAB 1000 iQ Powder coated	230V	E2242A
FumeCAB 1000 iQ Powder coated	115V	E2241A

Replacement filter part numbers

Model	Part no.
Pre Filter	A1030249
Combined Filter	A0130250



Datasheet correct at time of publishing.

Where applicable, the carbon used in BOFA units is capable of removing a wide range of VOC's, however it is the responsibility of the user to ensure the carbon is suitable for their application. For specific applications, please contact us for details.

Think before you print! Please consider the environment before printing this document.



V Tech SMT Ltd

Vision House, Bandeath Industrial Estate, Throsk, Stirling, FK7 7NP

T: 0044 (0) 1786 813999 **F:** 0044 (0) 1786 813998

E: sales@vtech-smt.co.uk **W:** www.vtech-smt.co.uk