



A Donaldson Company

A WORLD LEADER IN FUME EXTRACTION TECHNOLOGY



V 1000 iQ

ELECTRONICS

Last Updated on 29.08.2018



High volume extraction for hand and machine soldering applications.

BOFA's V 1000 iQ high end extraction system combines extremely large filter capacity with high airflow and pressure rates, making it the ideal choice for heavy duty applications that generate large amounts of particulate and gaseous organic compounds. This unit can cater for up to 15 operators (dependent on installation) as a centralised system or can be used to extract fumes from automated soldering machines.

Performance has now been further enhanced with the inclusion of several new features including BOFA's iQ Operating System, making the new V1000 iQ one of the most advanced systems available.

The iQ system takes performance and safety parameters to a new level and ensures that maintenance, downtime and ownership costs are kept to a minimum.

More information about the [Intelligent \(iQ\) Operating System](#).

Technology



Intelligent (iQ) operating system



DeepPleat DUO pre-filter



HEPA filter



Automatic flow control (AFC) technology



Reverse flow air (RFA) technology



Advanced carbon filter (ACF) technology



Patented technology



ProTECT service plan



SureCHECK quality standard

Key features of the V 1000 iQ

iQ Operating System
Standard

Reverse flow air filter technology (RFA)
Standard

Automatic flow control system
Standard

High contrast display
Standard

Remote diagnostics via USB
Standard

High airflow and pressure rates
Standard

DeepPleat DUO pre-filter
Standard

Real time airflow reading
Standard

'Run safe' operation
Standard

Independent filter condition monitoring, display and warnings
Standard



Combined HEPA/Gas filter incorporating ACF technology
Standard

VOC gas sensor (Volatile Organic Compound)
Optional

Interfacing with host machine
Optional

Filters with long life and low replacement cost
Standard

Remote stop / start interface
Optional

On-board compressor
Optional

Technical specification

1. iQ Display

2. On / off switch

3. Power cable

4. Signal / interface cable

5. Castors

6. Door hinge

7. Hose inlet connection -
125mm

8. Exhaust outlet

9. Motor cooling inlet

10. Door latch

11. Motor cooling outlet

12. Standby button

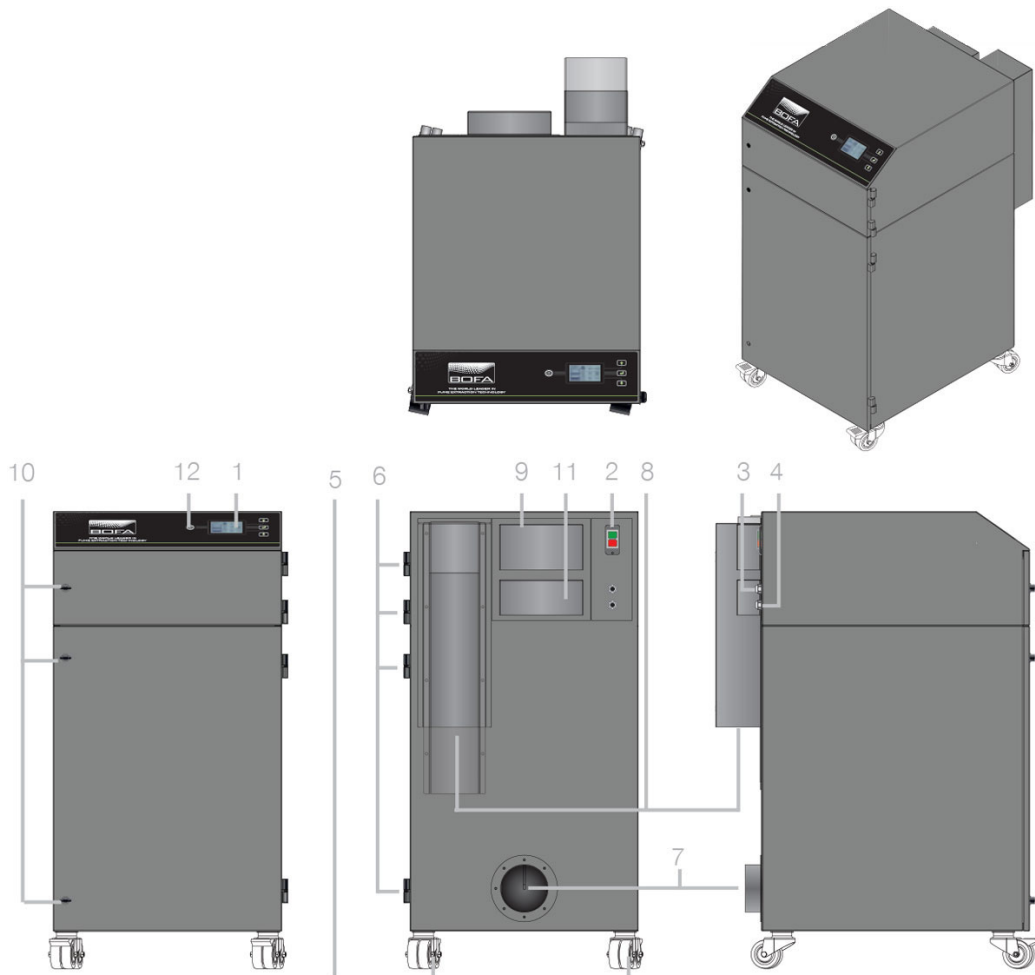

Airflow through filters

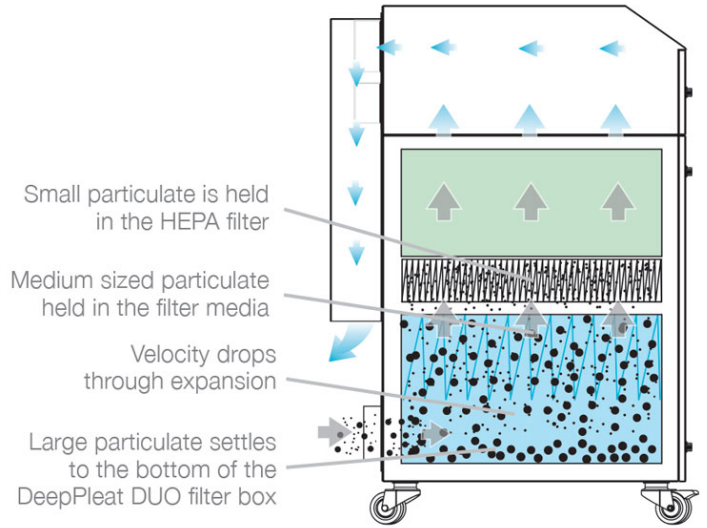
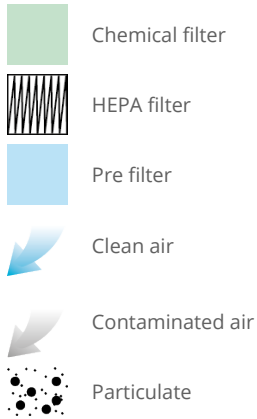

Technical data		
	EU	US
Dimensions (HxWxD)	1205 x 615 x 790mm	47.44 x 24.21 x 31.10"
Cabinet construction	Brushed stainless steel / Powder coated mild steel	Brushed stainless steel / Powder coated mild steel
Airflow / pressure	850m ³ /hr / 100mbar	500cfm / 100mbar
Electrical data	230v 1ph 50/60Hz Full load current: 12.8 amps / 2.2kw	115v 60/50Hz Full load current: 19.5 amps / 2.2kw
Noise level	< 63dBA (at typical operating speed)	< 63dBA (at typical operating speed)
	< 58dBA - with rear silencing boxes fitted (at typical operating speed)	< 58dBA - with rear silencing boxes fitted (at typical operating speed)
Weight	146kgs	321.88lbs
Approvals	CE	CE, cUL, UL

DeepPleat DUO pre-filter specifications	
Surface media area	30m ² approx (322.8ft ²)
Filter media	Borosilicate
Filter media construction	Maxi Pleat construction with glue bead spacers
Filter housing	Zintec mild steel
Filter efficiency	F8 (95% @ 0.9 microns)
Inlet size	125mm
Dropout chamber size	58 litres
Filter media pleat size	200mm

Combined HEPA/Gas filter specifications	
Surface media area	7.5m ² approx (80.7 ft ²)
HEPA filter media	Borosilicate
HEPA media construction	Maxi Pleat construction with glue bead spacers

Combined HEPA/Gas filter specifications

Filter housing	Zintec mild steel
Treated activated carbon	34kgs (74.8 lbs)
Filter efficiency	99.997% @ 0.3 microns

Unit part numbers

Model	Voltage	Part number	24v Stop/Start	VOC monitoring	On-board compressor
V 1000 iQ Stainless steel	230v	E1272	A2001	A2003	A2007
V 1000 iQ Stainless steel	115v	E1271	A2001	A2003	A2007
V 1000 iQ Powder coated	230v	E1262	A2001	A2003	A2007
V 1000 iQ Powder coated	115v	E1261	A2001	A2003	A2007

Replacement filters part numbers

Model	DeepPleat DUO pre-filter	Combined HEPA/Gas filter
V 1000 iQ	A1030397	A1030398

* Certain product configurations may affect the UL certification. Please speak to your sales representative.

Other languages

V 1000 iQ
[French](#)

Datasheet correct at time of publishing.

Where applicable, the carbon used in BOFA units is capable of removing a wide range of VOC's, however it is the responsibility of the user to ensure the carbon is suitable for their application. For specific applications, please contact us for details.

Think before you print! Please consider the environment before printing this document.



V Tech SMT Ltd

Vision House, Bandeath Industrial Estate, Throsk, Stirling, FK7 7NP

T: 0044 (0) 1786 813999 **F:** 0044 (0) 1786 813998

E: sales@vtech-smt.co.uk **W:** www.vtech-smt.co.uk